

Céliane™ Plaques finition Métal

Référence(s) : 0 667 81/82/83/91/92/93
0 687 11/12/13/14/18/19/ 81/82/83/84/91/92/93/94
0 689 50/71/72/73/74/75/76/78/79/80/81/82/83
0 689 84/85/86/88/89/90/91/92/93/94/98/99

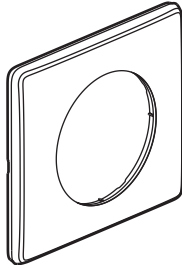

0 667 81/91 - 0 687 11/81/91 - 0 689 71/81/91

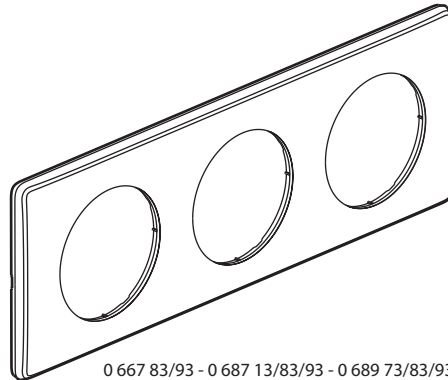





0 667 83/93 - 0 687 13/83/93 - 0 689 73/83/93

1. USAGE

Plaques permettant l'habillage de mécanismes de 1 à 6 postes.
Montage horizontal ou vertical.

2. GAMME





Plaques 1 poste

	<ul style="list-style-type: none">  Alu naturel  Alu chocolat  Violet irisé  Nuit d'encre  Laiton  Tungstene  Carbone  Copper 	<p>0 667 81 0 667 91 0 687 11 0 687 81 0 687 91 0 689 71 0 689 81 0 689 91</p>
---	---	--

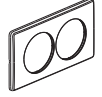

Plaques 2 postes - Entraxe 71 mm

	<ul style="list-style-type: none">  Alu naturel  Alu chocolat  Violet irisé  Nuit d'encre  Laiton  Tungstene  Carbone  Copper 	<p>0 667 82 0 667 92 0 687 12 0 687 82 0 687 92 0 689 72 0 689 82 0 689 92</p>
---	---	--

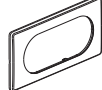

Plaques 2 postes - Entraxe 57 mm

	<ul style="list-style-type: none">  Violet irisé  Tungstene  Carbone  Copper 	<p>0 687 18 0 689 78 0 689 88 0 689 98</p>
---	--	--

Plaque 2 postes étendue

	<ul style="list-style-type: none">  Tungstene  Carbone 	<p>0 689 75 0 689 85</p>
---	--	------------------------------

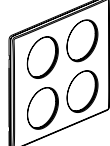
Plaque 2 x 2 postes





	<ul style="list-style-type: none">  Carbone 	<p>0 689 50</p>
---	---	-----------------

2. GAMME (suite)

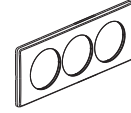

Plaques 3 postes - Entraxe 71 mm

	<ul style="list-style-type: none">  Alu naturel  Alu chocolat  Violet irisé  Nuit d'encre  Laiton  Tungstene  Carbone  Copper 	<p>0 667 83 0 667 93 0 687 13 0 687 83 0 687 93 0 689 73 0 689 83 0 689 93</p>
--	--	--

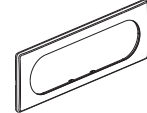

Plaques 3 postes - Entraxe 57 mm

	<ul style="list-style-type: none">  Violet irisé  Tungstene  Carbone  Copper 	<p>0 687 19 0 689 79 0 689 89 0 689 99</p>
---	--	--





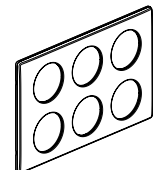

Plaque 3 postes étendue

	<ul style="list-style-type: none">  Tungstene  Carbone 	<p>0 689 76 0 689 86</p>
---	--	------------------------------

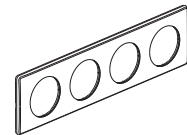

Plaque 3 x 3 postes

	<ul style="list-style-type: none">  Carbone 	<p>0 689 90</p>
---	---	-----------------

Plaque 4 postes - Entraxe 71 mm

	<ul style="list-style-type: none">  Violet irisé  Nuit d'encre  Laiton  Tungstene  Carbone  Copper 	<p>0 687 14 0 687 84 0 687 94 0 689 74 0 689 84 0 689 94</p>
--	--	--

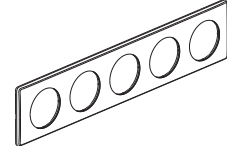
Plaque 5 postes - Entraxe 71 mm

	<ul style="list-style-type: none">  Carbone 	<p>0 689 80</p>
--	---	-----------------

3. DIMENSIONS (mm)

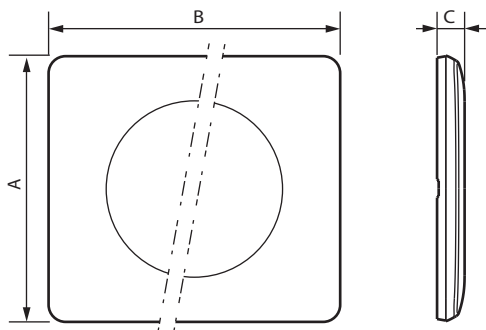

Références	A	B	C
0 667 81/91 - 0 687 11/81/91 - 0 689 71/81/91	82	90	8,5
0 667 82/92 - 0 687 12/82/92 - 0 689 72/75/82/85/92	82	161	8,5
0 667 83/90 - 0 687 13/83/93 - 0 689 73/76/83/86/93	82	232	8,5
0 687 14/84/94 - 0 689 74/84/94	82	303	8,5
0 687 18 - 0 689 78/88/98	82	147	8,5
0 687 19 - 0 689 79/89/99	82	204	8,5
0 689 50	159	175	8,5
0 689 90	159	246	8,5
0 689 80	82	374	8,5

4. CARACTÉRISTIQUES TECHNIQUES

■ 4.1 Caractéristiques matières

ABS + métal

Sans halogène

Résistant aux UV

Autoextinguibilité : 650° C/30 s

■ 4.2 Caractéristiques climatiques

Température de stockage : - 10° C à + 70° C

5. ENTRETIEN

Nettoyage superficiel au chiffon.

Ne pas utiliser : acétone, dégraissant, trichloréthylène.

Tenue aux produits suivants : Hexane (EN 60669-1), Alcool à brûler, Eau savonneuse, Ammoniac dilué, Javel pure diluée à 10%, Produit à vitres, Lingettes pré-imprégnées.

Attention : Pour l'utilisation de produits d'entretien spécifiques autres, un essai préalable est nécessaire.

6. UTILISATION PARTICULIERE

Aucune peinture ne doit être appliquée sur les plaques.